

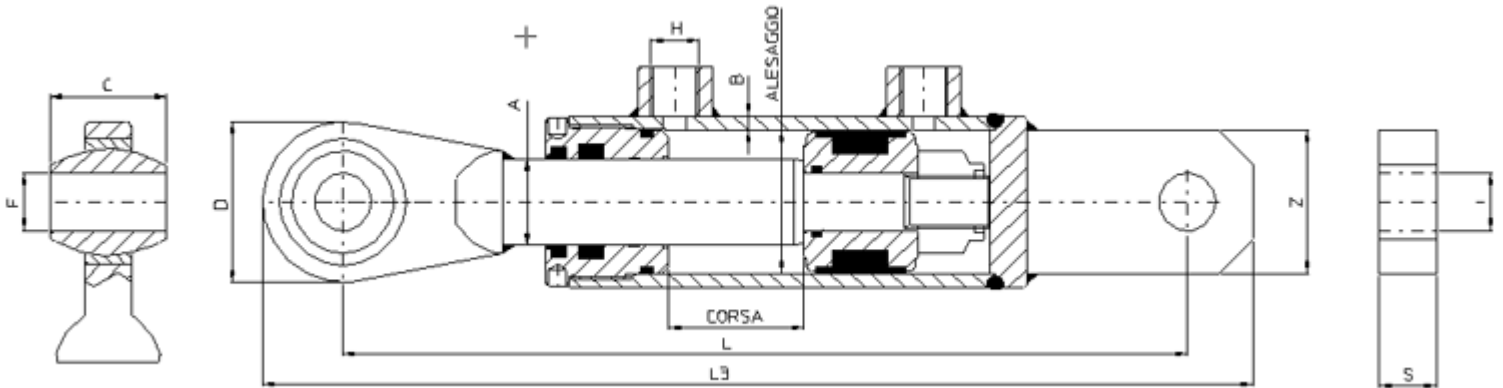

CILINDRO ESTANDARD DE DOBLE EFECTO CSSM

CILINDRO STANDARD DOPPIO EFFETTO CSSM	PRESSIONE DI ESERCIZIO MAX 220 bar
STANDARD DOUBLE ACTING CYLINDER CSSM	WORKING PRESSURE MAX 220 bar
VERIEN DOUBLE EFFET STANDARD CSSM	PRESSION DE SERVICE MAX 220 bar
DOPPELTWIRKENDER STANDARDZYLINDER CSSM	BETRIEBSDRUCK MAX 220 bar
CILINDRO ESTANDARD DE DOBLE EFECTO CSSM	PRESION DE TRABAJO MAX 220 bar



CODIGO	DIÁMETRO INTERIOR	A	CARRERA	L3	L	øi	S	Z	F	D	C	B	H
CSSM 3018100	30	18	100	352	311	16,2	20	30	16	46	20	5	1/4"
CSSM 3018150	30	18	150	402	361	16,2	20	30	16	46	20	5	1/4"
CSSM 3018200	30	18	200	452	411	16,2	20	30	16	46	20	5	1/4"
CSSM 3018250	30	18	250	502	461	16,2	20	30	16	46	20	5	1/4"
CSSM 3018300	30	18	300	552	511	16,2	20	30	16	46	20	5	1/4"
CSSM 3018350	30	18	350	602	561	16,2	20	30	16	46	20	5	1/4"
CSSM 3018400	30	18	400	652	611	16,2	20	30	16	46	20	5	1/4"
CSSM 40--100	40	20-25	100	368	318	20,2	25	40	20,3	58	44	5	1/4"
CSSM 40--150	40	20-25	150	418	368	20,2	25	40	20,3	58	44	5	1/4"
CSSM 40--200	40	20-25	200	468	418	20,2	25	40	20,3	58	44	5	1/4"
CSSM 40--250	40	20-25	250	518	468	20,2	25	40	20,3	58	44	5	1/4"
CSSM 40--300	40	20-25	300	568	518	20,2	25	40	20,3	58	44	5	1/4"
CSSM 40--350	40	20-25	350	618	568	20,2	25	40	20,3	58	44	5	1/4"
CSSM 40--400	40	20-25	400	668	618	20,2	25	40	20,3	58	44	5	1/4"
CSSM 40--450	40	20-25	450	718	668	20,2	25	40	20,3	58	44	5	1/4"
CSSM 40--500	40	20-25	500	768	718	20,2	25	40	20,3	58	44	5	1/4"

CSSM 40--600	40	20-25	600	868	818	20,2	25	40	20,3	58	44	5	1/4"
CSSM 50--100	50	25-30	100	375	325	20,2	25	40	20,3	58	44	5	3/8"
CSSM 50--150	50	25-30	150	425	375	20,2	25	40	20,3	58	44	5	3/8"
CSSM 50--200	50	25-30	200	475	425	20,2	25	40	20,3	58	44	5	3/8"
CSSM 50--250	50	25-30	250	525	475	20,2	25	40	20,3	58	44	5	3/8"
CSSM 50--300	50	25-30	300	575	525	20,2	25	40	20,3	58	44	5	3/8"
CSSM 50--350	50	25-30	350	625	575	20,2	25	40	20,3	58	44	5	3/8"
CSSM 50--400	50	25-30	400	675	625	20,2	25	40	20,3	58	44	5	3/8"
CSSM 50--500	50	25-30	500	775	725	20,2	25	40	20,3	58	44	5	3/8"
CSSM 50--600	50	25-30	600	875	825	20,2	25	40	20,3	58	44	5	3/8"
CSSM 60--100	60	30-35-40	100	426	368	25,2	30	45	25,7	70	51	5	3/8"
CSSM 60--150	60	30-35-40	150	476	418	25,2	30	45	25,7	70	51	5	3/8"
CSSM 60--200	60	30-35-40	200	526	468	25,2	30	45	25,7	70	51	5	3/8"
CSSM 60--250	60	30-35-40	250	576	518	25,2	30	45	25,7	70	51	5	3/8"
CSSM 60--300	60	30-35-40	300	626	568	25,2	30	45	25,7	70	51	5	3/8"
CSSM 60--350	60	30-35-40	350	676	618	25,2	30	45	25,7	70	51	5	3/8"
CSSM 60--400	60	30-35-40	400	726	668	25,2	30	45	25,7	70	51	5	3/8"
CSSM 60--500	60	30-35-40	500	826	768	25,2	30	45	25,7	70	51	5	3/8"
CSSM 60--600	60	30-35-40	600	926	868	25,2	30	45	25,7	70	51	5	3/8"
CSSM 70--100	70	30-35-40	100	426	368	25,2	30	45	25,7	70	51	5	3/8"
CSSM 70--150	70	30-35-40	150	476	418	25,2	30	45	25,7	70	51	5	3/8"
CSSM 70--200	70	30-35-40	200	526	468	25,2	30	45	25,7	70	51	5	3/8"
CSSM 70--250	70	30-35-40	250	576	518	25,2	30	45	25,7	70	51	5	3/8"
CSSM 70--300	70	30-35-40	300	626	568	25,2	30	45	25,7	70	51	5	3/8"
CSSM 70--350	70	30-35-40	350	676	618	25,2	30	45	25,7	70	51	5	3/8"
CSSM 70--400	70	30-35-40	400	726	668	25,2	30	45	25,7	70	51	5	3/8"
CSSM 70--500	70	30-35-40	500	826	768	25,2	30	45	25,7	70	51	5	3/8"
CSSM 70--600	70	30-35-40	600	926	868	25,2	30	45	25,7	70	51	5	3/8"
CSSM 80--100	80	40-45-50	100	448	381	30,2	35	50	30	82	42	7,5	1/2"
CSSM 80--150	80	40-45-50	150	498	431	30,2	35	50	30	82	42	7,5	1/2"
CSSM 80--200	80	40-45-50	200	548	481	30,2	35	50	30	82	42	7,5	1/2"
CSSM 80--250	80	40-45-50	250	598	531	30,2	35	50	30	82	42	7,5	1/2"
CSSM 80--300	80	40-45-50	300	648	581	30,2	35	50	30	82	42	7,5	1/2"
CSSM 80--350	80	40-45-50	350	698	631	30,2	35	50	30	82	42	7,5	1/2"
CSSM 80--400	80	40-45-50	400	748	681	30,2	35	50	30	82	42	7,5	1/2"
CSSM 80--500	80	40-45-50	500	848	781	30,2	35	50	30	82	42	7,5	1/2"
CSSM 80--600	80	40-45-50	600	948	881	30,2	35	50	30	82	42	7,5	1/2"