



CILINDRO ESTANDARD DE DOBLE EFECTO CSF (A o P)

CILINDRO STANDARD DOPPIO EFFETTO CSF (A o P)	PRESSIONE DI ESERCIZIO MAX 220 bar
STANDARD DOUBLE ACTING CYLINDER CSF (A o P)	WORKING PRESSURE MAX 220 bar
VERIEN DOUBLE EFFET STANDARD CSF (A o P)	PRESSION DE SERVICE MAX 220 bar
DOPPELTWIRKENDER STANDARDZYLINDER CSF (A o P)	BETRIEBSDRUCK MAX 220 bar
CILINDRO ESTANDARD DE DOBLE EFECTO CSF (A o P)	PRESION DE TRABAJO MAX 220 bar

ESEMPIO D'ORDINE	EXAMPLE OF ORDER	EXEMPLE DE COMMANDE	BESTELLUNGSBELSPIEL	EJEMPLO DE ORDEN	= CSFP4025100
------------------	------------------	---------------------	---------------------	------------------	---------------

(C)	(S)	(F)	(A o P)	(40)	(25)	(100)
CILINDRO	STANDARD	FLANGIA	TIPO (A o P)	ALESAGGIO	Ø STELO	CORSA

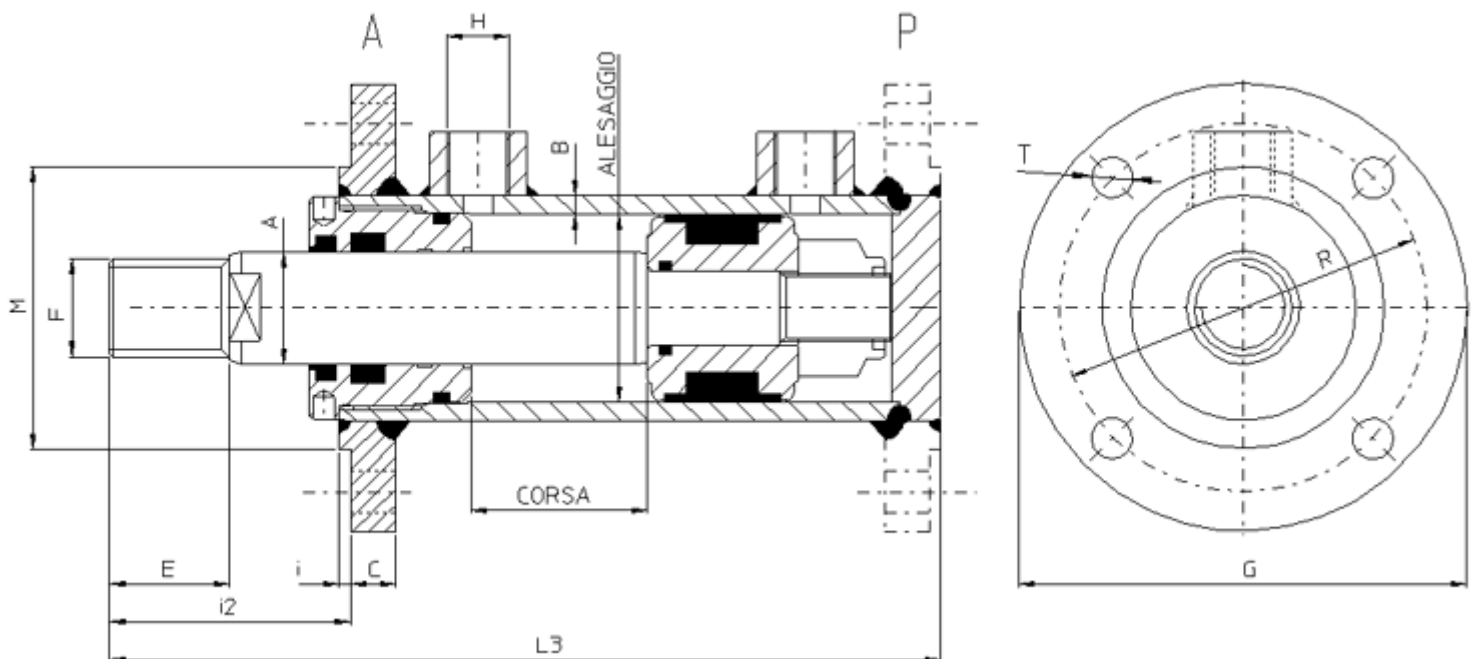

CODIGO	DIÁMETRO INTERIOR	A	CARRERA	L3	C	I	i2	E	F	B	T	R	G	H	M
--------	-------------------	---	---------	----	---	---	----	---	---	---	---	---	---	---	---

CSF 3018100	30	18	100	253	12	3	60	27	16x1,5	5	9	78	99	1/4 "	55
CSF 3018150	30	18	150	303	12	3	60	27	16x1,5	5	9	78	99	1/4 "	55
CSF 3018200	30	18	200	353	12	3	60	27	16x1,5	5	9	78	99	1/4 "	55
CSF 3018250	30	18	250	403	12	3	60	27	16x1,5	5	9	78	99	1/4 "	55
CSF 3018300	30	18	300	453	12	3	60	27	16x1,5	5	9	78	99	1/4 "	55
CSF 3018350	30	18	350	503	12	3	60	27	16x1,5	5	9	78	99	1/4 "	55
CSF 3018400	30	18	400	553	12	3	60	27	16x1,5	5	9	78	99	1/4 "	55
CSF 40--100	40	20-25	100	257	12	3	60	27	16x1,5-22x 1,5	5	9	88	109	1/4 "	65
CSF 40--150	40	20-25	150	307	12	3	60	27	16x1,5-22x 1,5	5	9	88	109	1/4 "	65
CSF 40--200	40	20-25	200	357	12	3	60	27	16x1,5-22x 1,5	5	9	88	109	1/4 "	65
CSF 40--250	40	20-25	250	407	12	3	60	27	16x1,5-22x 1,5	5	9	88	109	1/4 "	65
CSF 40--300	40	20-25	300	457	12	3	60	27	16x1,5-22x 1,5	5	9	88	109	1/4 "	65
CSF 40--350	40	20-25	350	507	12	3	60	27	16x1,5-22x 1,5	5	9	88	109	1/4 "	65
CSF 40--400	40	20-25	400	557	12	3	60	27	16x1,5-22x 1,5	5	9	88	109	1/4 "	65
CSF 50--100	50	25-30	100	269	12	3	65	32	22x1,5-28x 1,5	5	11	98	119	3/8 "	75
CSF 50--150	50	25-30	150	319	12	3	65	32	22x1,5-28x 1,5	5	11	98	119	3/8 "	75
CSF 50--200	50	25-30	200	369	12	3	65	32	22x1,5-28x 1,5	5	11	98	119	3/8 "	75
CSF 50--250	50	25-30	250	419	12	3	65	32	22x1,5-28x 1,5	5	11	98	119	3/8 "	75
CSF 50--300	50	25-30	300	469	12	3	65	32	22x1,5-28x 1,5	5	11	98	119	3/8 "	75
CSF 50--350	50	25-30	350	519	12	3	65	32	22x1,5-28x 1,5	5	11	98	119	3/8 "	75
CSF 50--400	50	25-30	400	569	12	3	65	32	22x1,5-28x 1,5	5	11	98	119	3/8 "	75
CSF	50	25-30	500	669	12	3	65	32	22x1,5-28x	5	11	98	119	3/8	75

50--500									1,5					"	
CSF 50--600	50	25-30	600	769	12	3	65	32	22x1,5-28x 1,5	5	11	98	119	3/8 "	75
CSF 60--100	60	30-35- 40	100	303	12	3	74	38	28x1,5-35x 1,5	5	11	108	129	3/8 "	85
CSF 60--150	60	30-35- 40	150	353	12	3	74	38	28x1,5-35x 1,5	5	11	108	129	3/8 "	85
CSF 60--200	60	30-35- 40	200	403	12	3	74	38	28x1,5-35x 1,5	5	11	108	129	3/8 "	85
CSF 60--250	60	30-35- 40	250	453	12	3	74	38	28x1,5-35x 1,5	5	11	108	129	3/8 "	85
CSF 60--300	60	30-35- 40	300	503	12	3	74	38	28x1,5-35x 1,5	5	11	108	129	3/8 "	85
CSF 60--350	60	30-35- 40	350	553	12	3	74	38	28x1,5-35x 1,5	5	11	108	129	3/8 "	85
CSF 60--400	60	30-35- 40	400	603	12	3	74	38	28x1,5-35x 1,5	5	11	108	129	3/8 "	85
CSF 60--500	60	30-35- 40	500	703	12	3	74	38	28x1,5-35x 1,5	5	11	108	129	3/8 "	85
CSF 60--600	60	30-35- 40	600	803	12	3	74	38	28x1,5-35x 1,5	5	11	108	129	3/8 "	85
CSF 70--100	70	30-35- 40	100	303	15	3	74	38	28x1,5-35x 1,5	5	13	124	149	3/8 "	95
CSF 70--150	70	30-35- 40	150	353	15	3	74	38	28x1,5-35x 1,5	5	13	124	149	3/8 "	95
CSF 70--200	70	30-35- 40	200	403	15	3	74	38	28x1,5-35x 1,5	5	13	124	149	3/8 "	95
CSF 70--250	70	30-35- 40	250	453	15	3	74	38	28x1,5-35x 1,5	5	13	124	149	3/8 "	95
CSF 70--300	70	30-35- 40	300	503	15	3	74	38	28x1,5-35x 1,5	5	13	124	149	3/8 "	95
CSF 70--350	70	30-35- 40	350	553	15	3	74	38	28x1,5-35x 1,5	5	13	124	149	3/8 "	95
CSF 70--400	70	30-35- 40	400	603	15	3	74	38	28x1,5-35x 1,5	5	13	124	149	3/8 "	95
CSF 70--500	70	30-35- 40	500	703	15	3	74	38	28x1,5-35x 1,5	5	13	124	149	3/8 "	95
CSF 70--600	70	30-35- 40	600	803	15	3	74	38	28x1,5-35x 1,5	5	13	124	149	3/8 "	95
CSF 80--100	80	40-45- 50	100	326	20	4	84	45	35x1,5-45x 1,5	7,5	15	134	164	1/2 "	110
CSF 80--150	80	40-45- 50	150	376	20	4	84	45	35x1,5-45x 1,5	7,5	15	134	164	1/2 "	110

CSF 80--200	80	40-45- 50	200	426	20	4	84	45	35x1,5-45x 1,5	7,5	15	134	164	1/2 "	110
CSF 80--250	80	40-45- 50	250	476	20	4	84	45	35x1,5-45x 1,5	7,5	15	134	164	1/2 "	110
CSF 80--300	80	40-45- 50	300	526	20	4	84	45	35x1,5-45x 1,5	7,5	15	134	164	1/2 "	110
CSF 80--350	80	40-45- 50	350	576	20	4	84	45	35x1,5-45x 1,5	7,5	15	134	164	1/2 "	110
CSF 80--400	80	40-45- 50	400	626	20	4	84	45	35x1,5-45x 1,5	7,5	15	134	164	1/2 "	110
CSF 80--500	80	40-45- 50	500	726	20	4	84	45	35x1,5-45x 1,5	7,5	15	134	164	1/2 "	110
CSF 80--600	80	40-45- 50	600	826	20	4	84	45	35x1,5-45x 1,5	7,5	15	134	164	1/2 "	110